



DATA SHEET
LLINK™-08 for IPG YLP series

NEWSON NV

Table of Contents

1	CONNECTIONS LLINK™	3
1.1	COMPATIBILITY	3
1.2	DIMENSIONS	3
1.3	INTERNAL SCHEME	4
1.4	POWER SUPPLY	4
1.5	CONNECTION EXAMPLES CUA - LLINK™ - 08	5
1.6	CONNECTION EXAMPLES CUA32-MST-XX - LLINK™ - 08	7
2	DLL LIBRARY FUNCTIONS	10
2.1	LLINK COMMANDS	10

1 CONNECTIONS LLINK™

The LLINK™ hardware provides an easy interface to lasers. A **single twisted pair** is the only connection between a CUA-control unit and the laser.

LLINK™-08 is built for the **IPG YLP-series**.

1.1 COMPATIBILITY

LLINK™-08 hardware supports IPG YLP series laser sources with following interface:

- Interface Specification "Type B", "Type B1" and "Type B2"
- Interface Specification "Type D" and "Type D1"
- Interface Specification "Type E"

1.2 DIMENSIONS

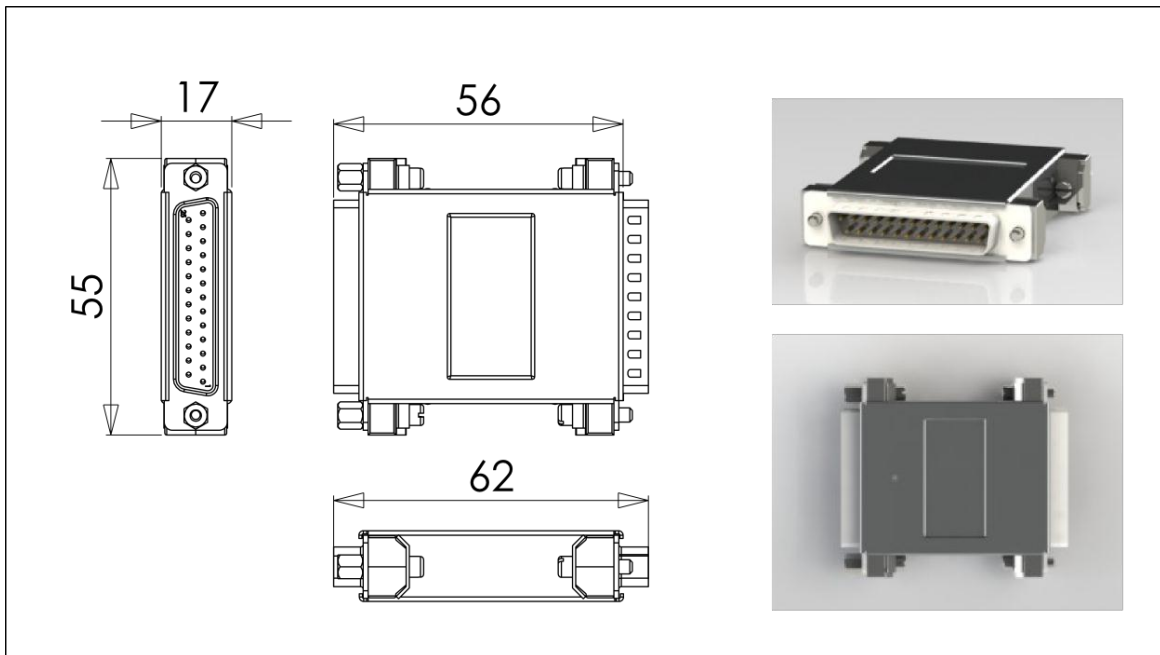

All dimensions are in mm.

The LLINK™ hardware has 2 connector sides.

One side is marked, IPG and should be directly plugged into the control connector of the IPG laser.

The other side is marked CUA.

1.3 INTERNAL SCHEME

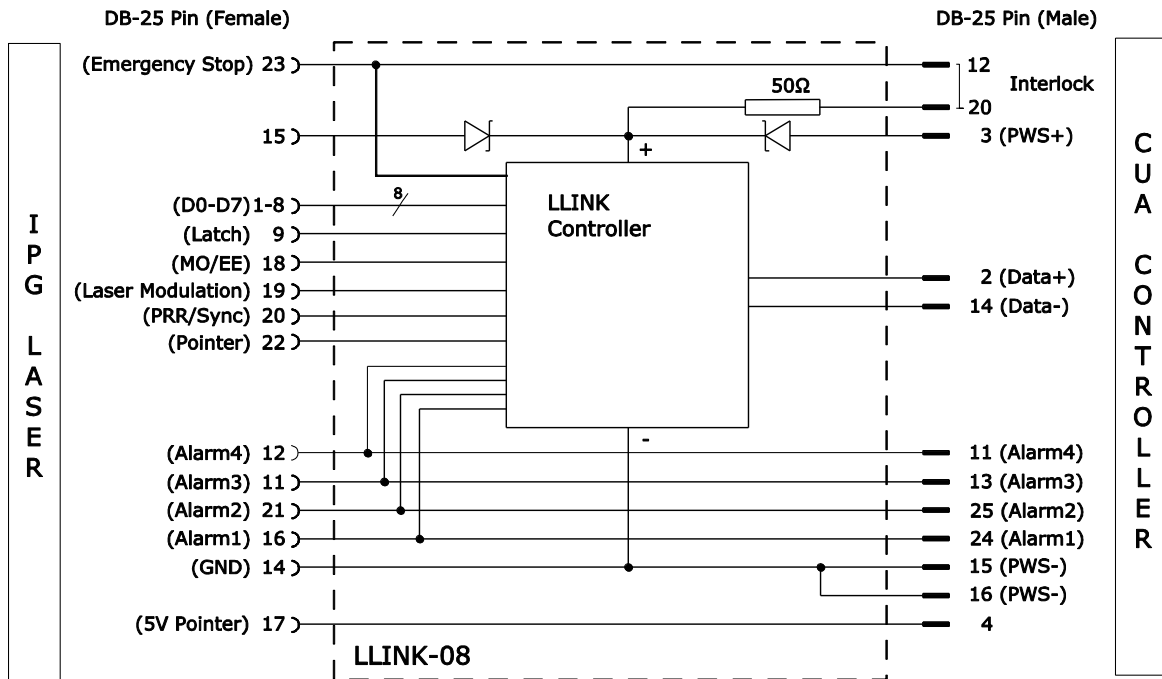

1.4 POWER SUPPLY

LLINK™ systems used with IPG lasers, comprising a “Type B” or “Type D” interface, need to be powered by a 5V DC power supply. Due to the specification of the IPG laser, this power supply needs to be floating (not connected to EARTH). The grounding of the power supply is done inside the laser.

YLP series Pulsed Fiber Lasers “Type E” have a 5V DC power output which can be used as power supply for the LLINK™. These laser types don’t need an external powering for the device.

WARNING

The LLINK™ is not protected against reverse polarity or overvoltage. Reverse polarisation or overvoltage will damage the system.

In order to minimize cost, one can use the 5V DC output of the CUA board. In order to be in compliance with the directives of IPG, the 12V power supply of the CUA needs to be floating. The connected motors and the CUA control board will be connected to earth through the Laser.

1.5 CONNECTION EXAMPLES CUA - LLINK™ - 08

1.5.1 Connect LLINK™ using external 5V, 100mA power supply

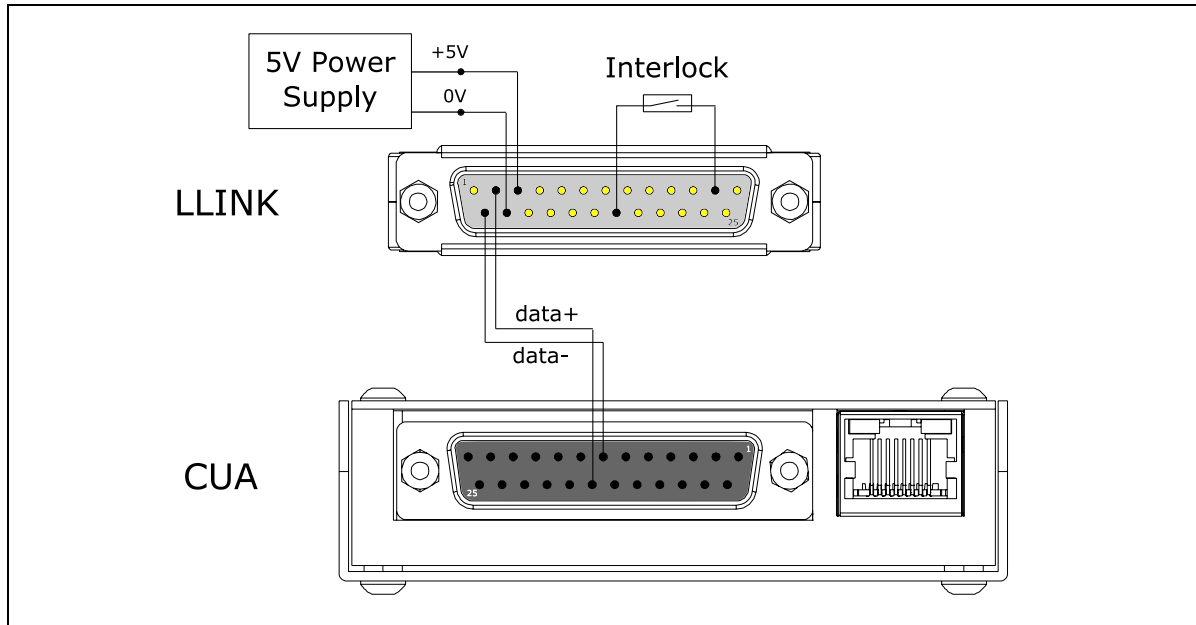

1.5.2 Connect LLINK™ using 5V power supply output of CUA

Remark: In this setup the CUA card needs to be floating (not connected to EARTH).

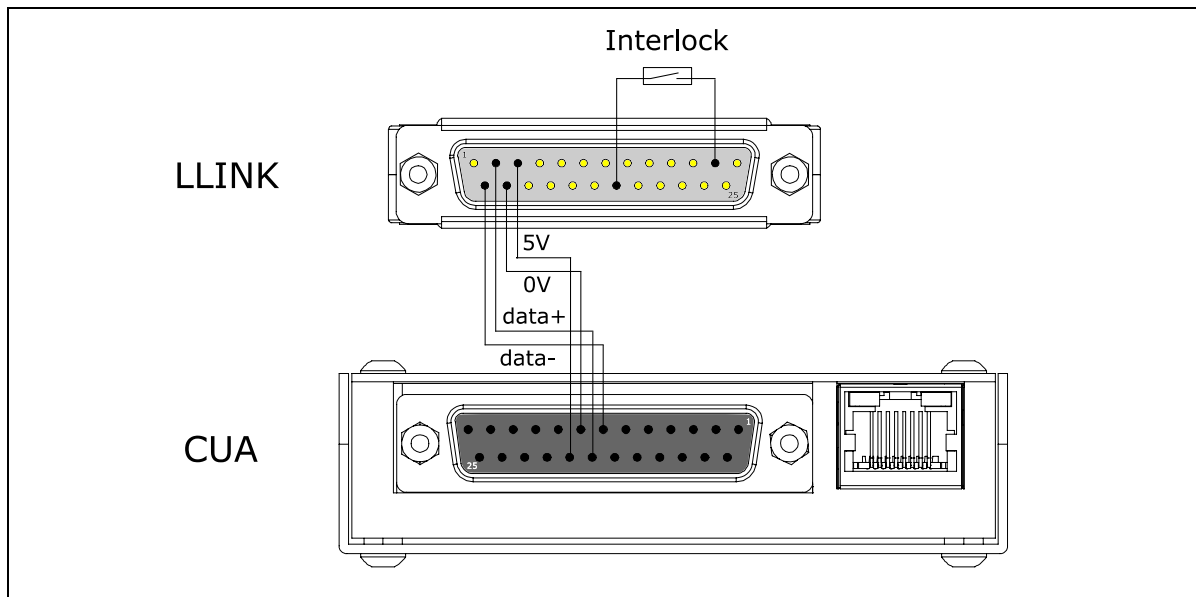

1.5.3 Connect LLINK™ using 5V power output of IPG laser (only “Type E” interface)

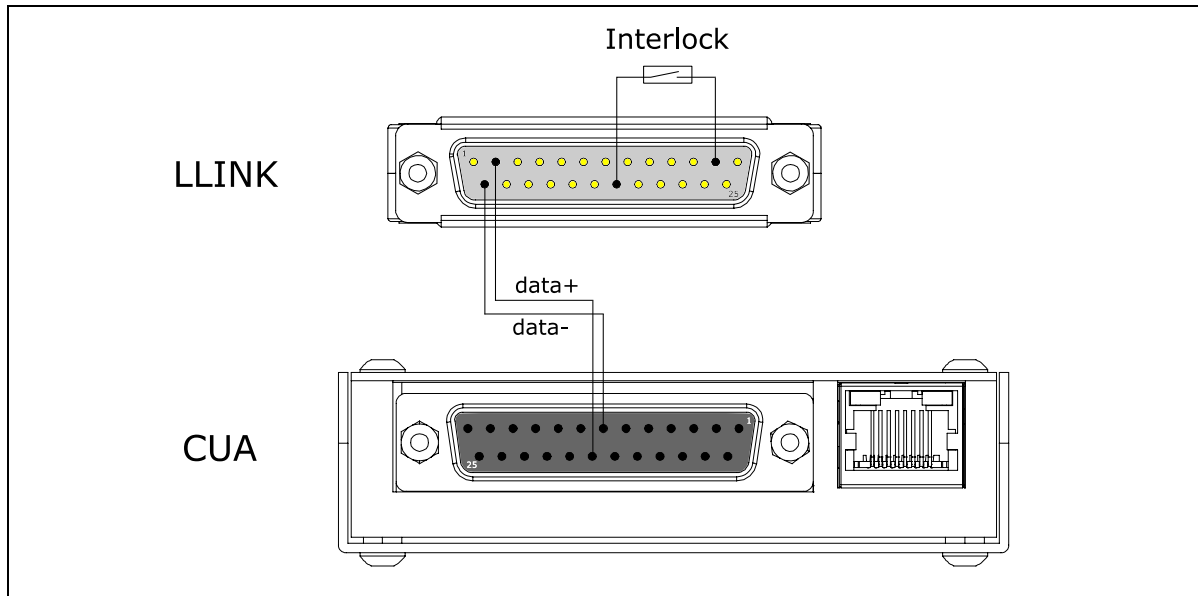

1.6 CONNECTION EXAMPLES CUA32-MST-XX - LLINK™ - 08

1.6.1 Connect LLINK™ using external 5V, 100mA power supply

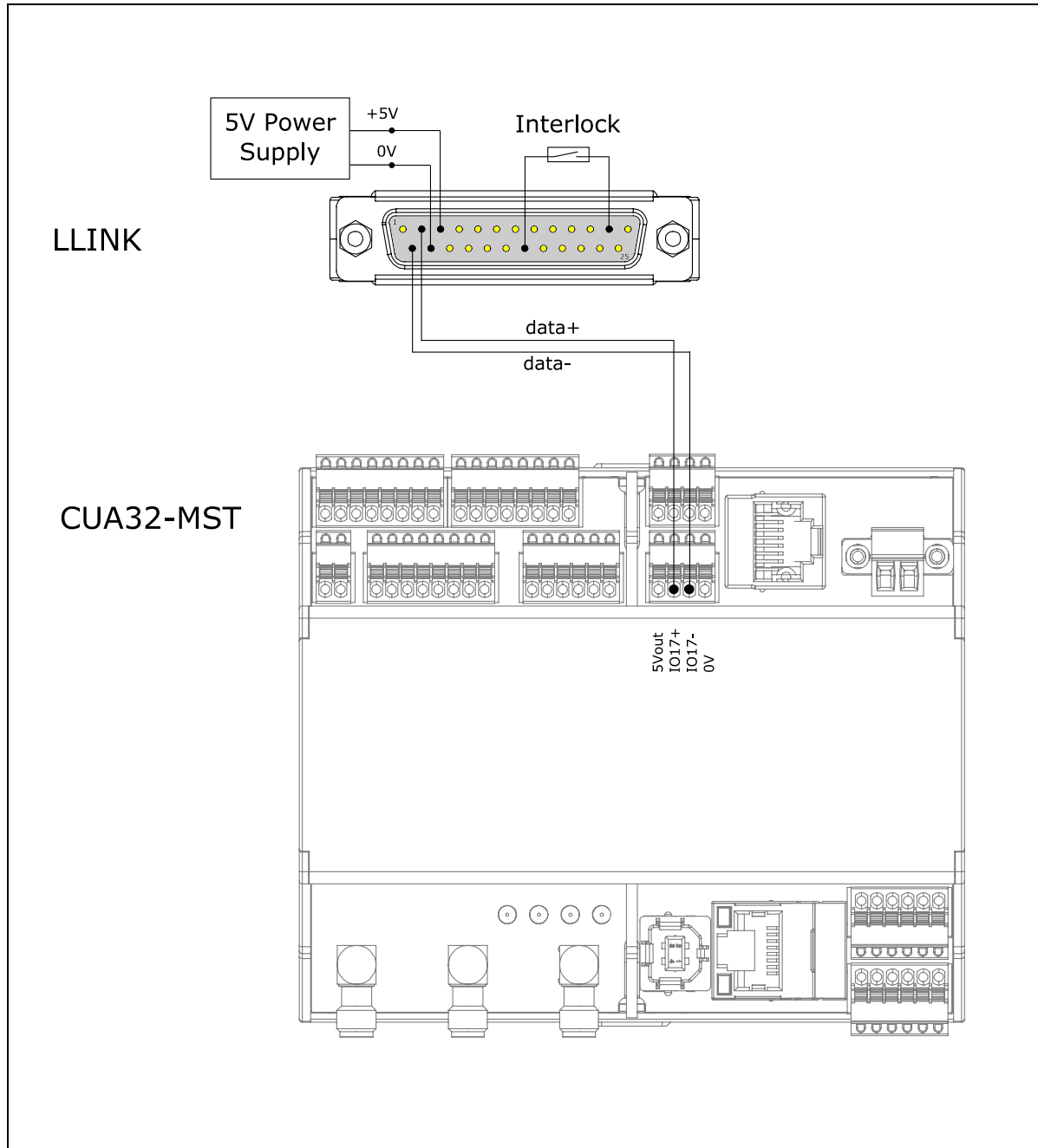

1.6.2 Connect LLink™ using 5V power supply output of CUA32-MST-XX controller

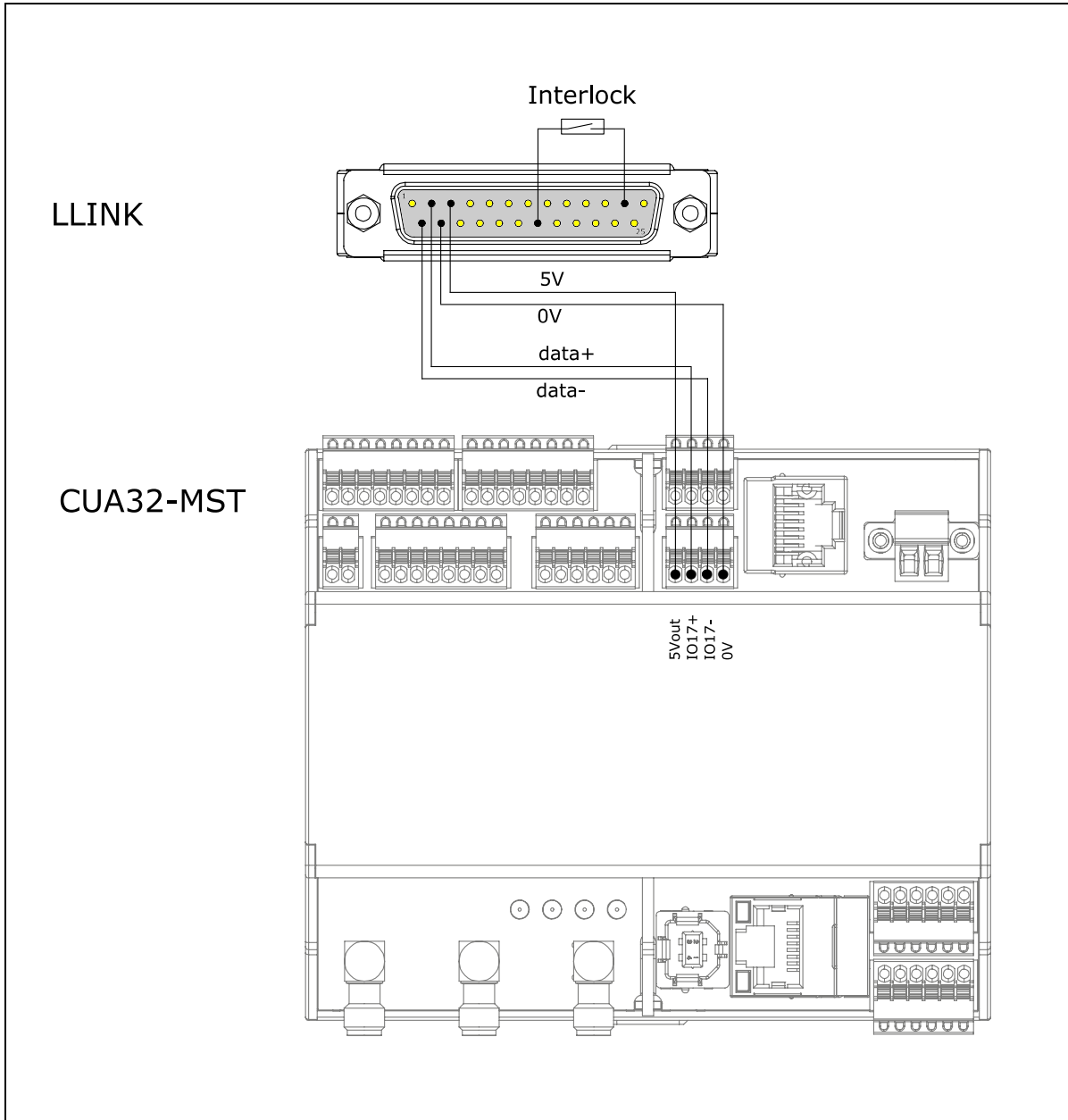

1.6.3 Connect LLink™ using 5V power output of IPG laser (only “Type E” interface)

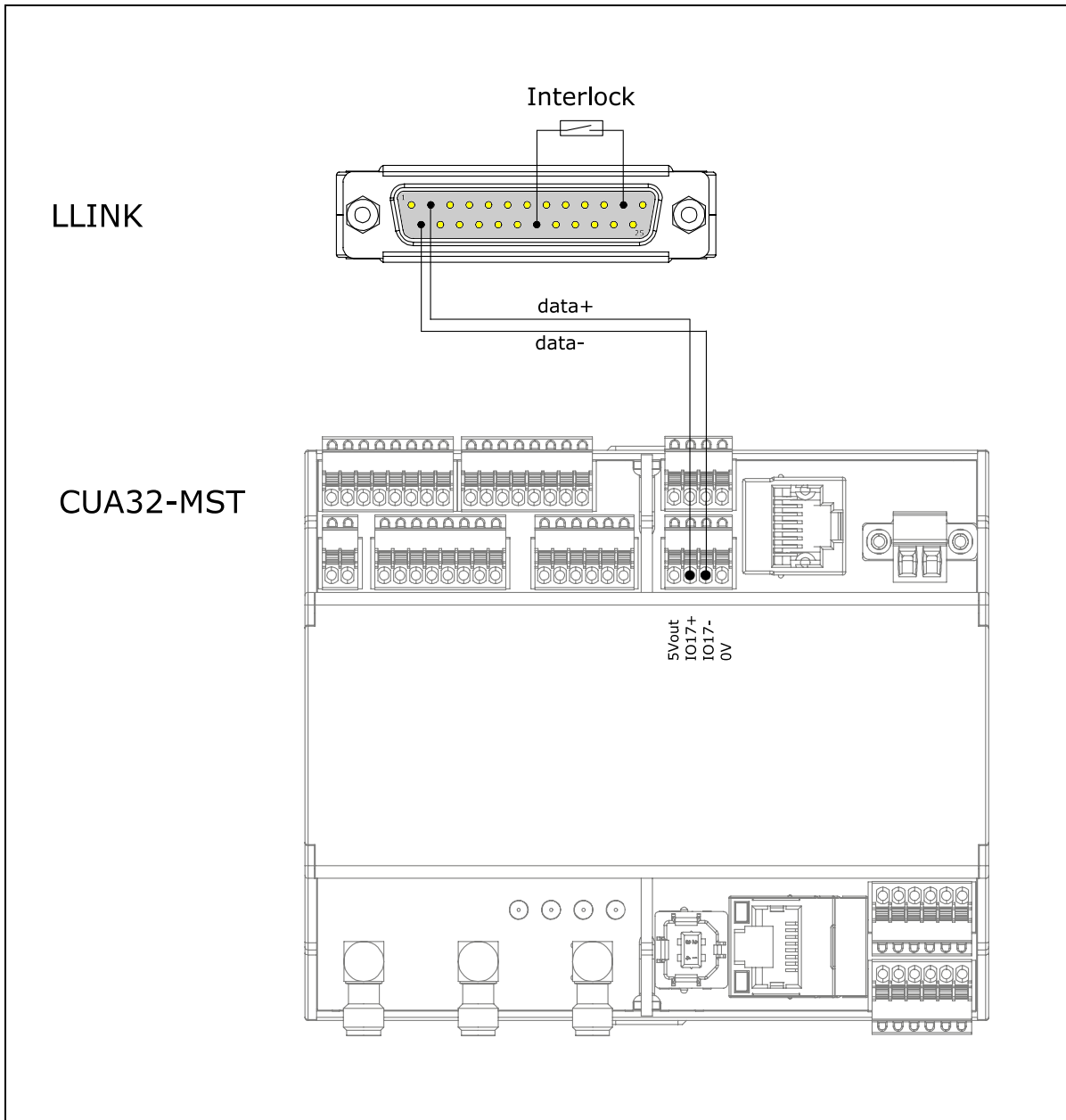

2 DLL LIBRARY FUNCTIONS

The LLINK™ hardware provides an easy interface to IPG lasers. A single twisted pair is the only connection between a CUA-control unit and the laser. All commands send to the LLINK™ are executed immediately. It's the responsibility of the machine application to verify needed timing and sequences to comply with the laser datasheet.

```
rtSetLaserLink(cmd,value)
rtGetLaserLink(cmd,&value)
```

In next example script EE/MO is activated, power is set to 50%, and the PRR/SYNC is set to a 25 kHz signal with a dutycycle of 60%.

```
rtListOpen(1)
rtSetLaserLink(3,1)
rtSleep(7000)
rtSetLaserLink(0,128)
rtSetLaserLink(1,25)
rtSetLaserLink(2,153)
rtListClose()
```

2.1 LLINK COMMANDS

Power Setting

```
command: rtSetLaserLink(0,value)
action:
1: copies value to pin 1..8 connector (power setting)
2: wait 1.8 µsec
3: set pin 9 (latch setting in laser)
4: wait 1.8 µsec
5: reset pin 9
```

Frequency Setting

```
command: rtSetLaserLink(1,value)
action: sets the Pulse Repetition rate. (pin 20)
value is frequency in KHz
```

DutyCycle

```
command: rtSetLaserLink(2,value)
action: sets the duty cycle of Pulse Repetition rate. (pin 20)
value 0 = 0%
value 255 = 100%
```

Emission Enable (EE) / Master Oscillator (MO)

```
command: rtSetLaserLink(3,value)
action
if bit0 of value is set, set pin 18 (EE/MO on)
if bit0 of value is cleared, reset pin 18 (EE/MO off)
```

NOTE: Laser Modulation Signal (pin 19) is only generated when EE/MO is enabled.

Guide Laser

command: `rtSetLaserLink(4,value)`
action
if bit0 of value is set, set pin 22 (Guide Laser on)
if bit0 of value is cleared, reset pin 22 (Guide Laser off)

Frequency Setting (10KHz steps)

command: `rtSetLaserLink(5,value)`
action: sets the Pulse Repetition rate. (pin 20)
value is frequency in 10KHz steps
(This function is only supported by LLink-08 with SN 11184 and above)

Query Laser Status bits

command: `rtGetLaserLink(1,&value)`
action: samples pin 11, 12, 16, 18, 19, 21, 22 and 23 status.
Bit0 of value indicates state of pin 16 (Alarm1)
Bit1 of value indicates state of pin 21 (Alarm2)
Bit2 of value indicates state of pin 11 (Alarm3)
Bit3 of value indicates state of pin 12 (Alarm4)
Bit4 of value indicates state of pin 23 (Emergency Stop)
Bit5 of value indicates state of pin 18 (MO/EE)
Bit6 of value indicates state of pin 19 (Laser Modulation)
Bit7 of value indicates state of pin 22 (Pointer)

Query LaserLink Type

command: `rtGetLaserLink(127,&value)`
value 0x08 : IPG-laser interface LLINK - 08